

MP - 400

THE MOBILE ROBOT MP-400 was designed for daily use in industrial applications. It combines well proven components with smart innovations to form a high-performance robot at an affordable price.

THE MP-400'S PRIMARY TASK is to support a flexible material flow in intralogistics. This small, agile robot can cover connections that cannot be realised with stationary conveyors or traditional AGVs. With its integrated laser scanner the MP-400 can safely and freely move between humans and without fixed routes. Its central differential drive and the compact, symmetric design allow the robot to find its way even in very narrow environments.

MANY DIFFERENT OPTIONS can be chosen to adjust the MP-400 to almost any given application, reaching from simple transport with an integrated load handling device to high-class research with additional robot arm and sensors.



INCLUDED IN DELIVERY

- Mobile platform
- 1 x Sick S300 safety laser scanner
- Battery pack
- Wireless joystick
- Manual charger
- On-board computer
- Software package ROS
- Documentation
- CE Declaration of Conformity

OPTIONS

- Battery quick change system
- Automatic charging station
- Load handling device
- High payload of 150 kg
- 6 x ultrasonic sensors
- Intel i7 on-board computer
- IOBoard
- Audio system

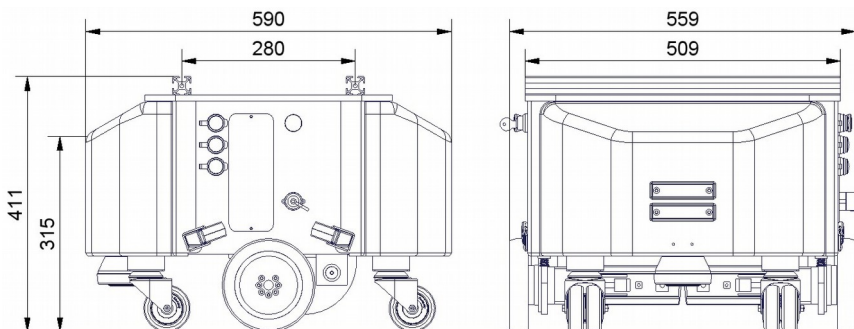

TECHNICAL DATA

Payload	100 kg (optional: high payload of 150 kg)
Weight	approx. 70 kg
Ground clearance	44 mm
Speed	< 1.5 m/s
Battery pack	AGM sealed lead acid 24 V / 50 Ah
Uptime / charge time	approx. 10 h / 6 h
Sensors	Laser scanner Sick S300 Expert (optional: 6 x ultrasonic sensors)
Computer	Intel i5, 8 GB RAM, > 200 GB SSD, WLAN