

MMO-500

THE MOBILE MANIPULATOR MMO-500 combines the omnidirectional MPO-500 with a light-weight robot arm from Universal Robots or Schunk.

ITS MECANUM WHEELS allow the MMO-500 to move freely into any direction which significantly enlarges the workspace of the integrated arm.

THE MMO-500 CAN INTEGRATE most of the available light-weight robot arms and is especially suited for the arms LWA4P or LWA4D from Schunk or the arms UR5 and UR10 from Universal Robots.

THE PLATFORM CAN BE CONTROLLED BY the free Robot Operating System (ROS) or Neobotix PlatformCtrl. The Universal Robots arms can be controlled with their original control software. The Schunk light weight arms can be controlled by the free Robot Operating System (ROS).

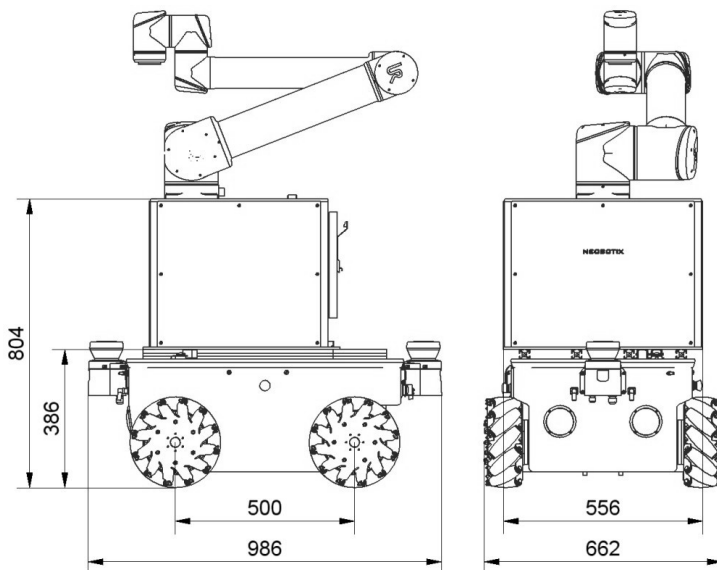

INCLUDED IN DELIVERY

- Mobile platform
- Battery pack
- 1 x Sick S300 safety laser scanner
- Wireless joystick
- Manual charger
- On-board computer
- Software package PlatformCtrl / ROS
- Documentation

OPTIONS

- Integration of a robot arm
- 2nd laser scanner Sick S300
- Battery quick change system
- Automatic charging station
- High payload of 150 kg
- Intel i7 on-board computer
- IOBoard
- Audio system

PLATFORM'S TECHNICAL DATA

Payload	50 kg (optional: high payload of 150 kg)
Weight	approx. 150 kg
Ground clearance	45 mm (with charging contacts: 35 mm)
Speed	< 0.8 m/s
Battery pack	AGM sealed lead acid 24 V / 50 Ah
Uptime / charge time	approx. 6 h / 6 h
Sensors	Laser scanner Sick S300 Expert (optional: 2 nd laser scanner Sick S300 Expert)
Computer	Intel i5, 8 GB RAM, > 200 GB SSD, WLAN