

MMO ▶ 500

4. Mär 2026

DATA SHEET

The mobile manipulator **MMO-500** combines the omnidirectional MPO-500 with a light-weight robot arm from Universal Robots or Elite Robots.

Its Mecanum wheels allow the **MMO-500** to move freely into any direction which significantly enlarges the workspace of the integrated arm.

The **MMO-500** can integrate most of the available light-weight robot arms and is especially suited for the arms UR5e and UR10e from Universal Robots.

The default manipulator configuration already contains everything needed for immediate operation, from extended battery capacity to all basic software packages. For optimal usability a wide range of options is available, like a wireless emergency stop, our IOBoard and more.

To match your individual requirements the **MMO-500** can also be heavily customised and engineered into a bespoke mobile robot system, perfect for your unique application.

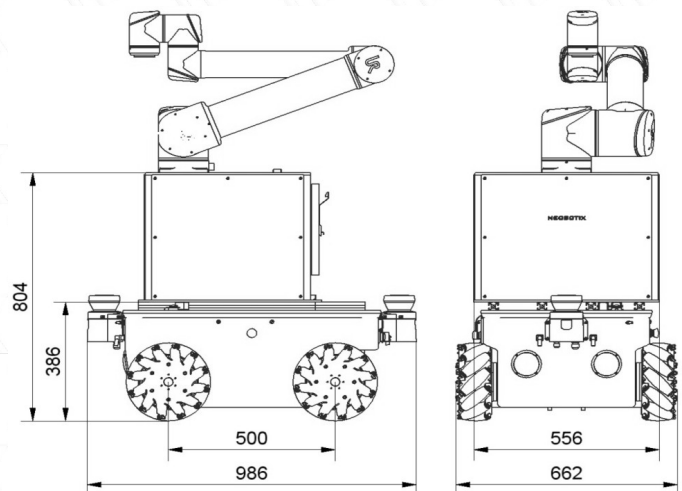

▶ PAYLOAD ARM / PLATFORM

Up to 12 kg / 30 kg

▶ WEIGHT

200 kg

▶ SENSORS

1 x Laser scanner Sick S300 Expert
Option: 2nd Sick S300 Expert

▶ SPEED

< 0.8 m/s

▶ UPTIME / CHARGE TIME

approx. 6 h / 6 h

▶ COMPUTER

Intel i5, 8 GB RAM, > 200 GB SSD, WLAN
Option: Intel i7, 16 GB RAM, > 400 GB SSD